

OVERVIEW

# COMPANY

and PRODUCTS  
LINES



## Company

INTRAC operates in the field of shopfitting and serves the small, medium and large scale distribution.

INTRAC was born as a trademark in 1997, but has got deeper roots. The origin is ARNEG Spa, the parent company, worldwide leader in the production of refrigerated cabinets, shelving equipment and cold rooms for the small and large scale distribution.

INTRAC, acronym of "International Rack", situated in Rovigo since 1999, the factory was built on a surface of more than 100.000 square metres, of which 45.000 are covered to house the manufacturing plant, the offices and the showroom.

Production includes shelving and check-out counters for any commercial purpose, from specialised to non-specialised stores. Metal processing plants are of advanced conception, moulding and folding lines are among the most modern in the market, and the epoxy powder coating plant complies with the more rigid safety and environmental standards.

INTRAC is certified according to EN ISO 9001:2008 and EN ISO 14001:2004 and applies monitoring systems on all its manufacturing processes, by means of a continuous and complete analysis at each and every working stage and applies a policy of continuous improvement on its Environmental Management System. The range of the products is wide and complete, studied and developed in all his details to be able to customize the offer and respond to all the expectation of our customers.



## Production

The production of shelving consist of 7 lines:

IMZ25, commercial shelving system with an upright pitch of 25 mm.

JANUS EVO, commercial shelving system with a single central back panel based upon the IMZ25 shelving line.

AMX35evo, commercial shelving system with an upright pitch of 35 mm.

MULTIFORM, multi-purpose shelving system in tubular steel 40x40.

IWL25 RTBevo, wooden customization of the IMZ25 shelving line.

DOGMA25-i60, heavy duty shelving integrated with the IMZ25 shelving line.

DOGMA st-60, st-90, heavy duty shelving lines.

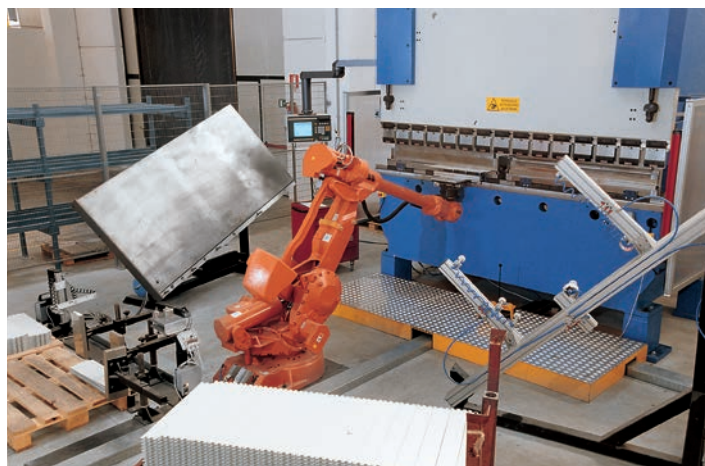
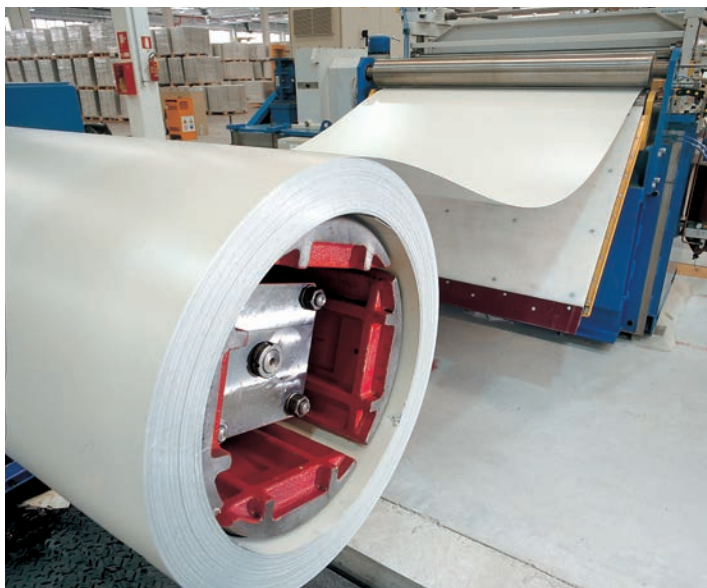

IMZ25, commercial shelving system with an upright pitch of 25 mm.



JANUS EVO, shelving system with a single central back panel based upon the IMZ25 shelving line.

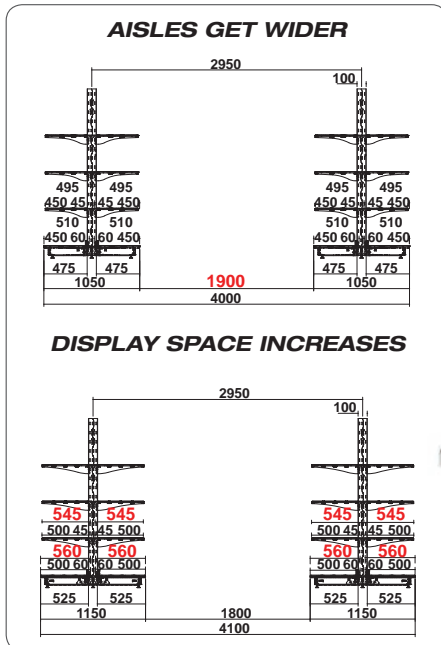

**GONDOLA VERSION  
SINGLE BACK PANEL**

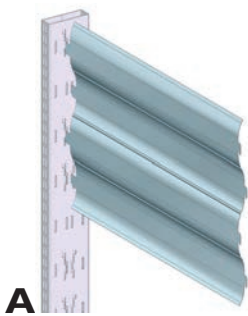

**WALL VERSION  
SINGLE BACK PANEL**

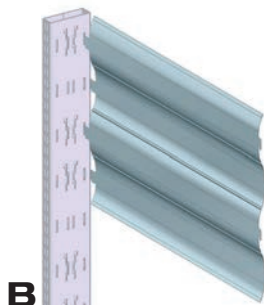

AMX35evo, commercial shelving system with an upright pitch of 35 mm.





MULTIFORM, multi-purpose shelving system in tubular steel 40x40.

Cartoleria  
Stationery



Profumeria  
Perfumery



Moda  
Fashion



Giocattoli  
Toys

Arredocasa  
Home accessories



Parafarmacia  
Parapharmacy

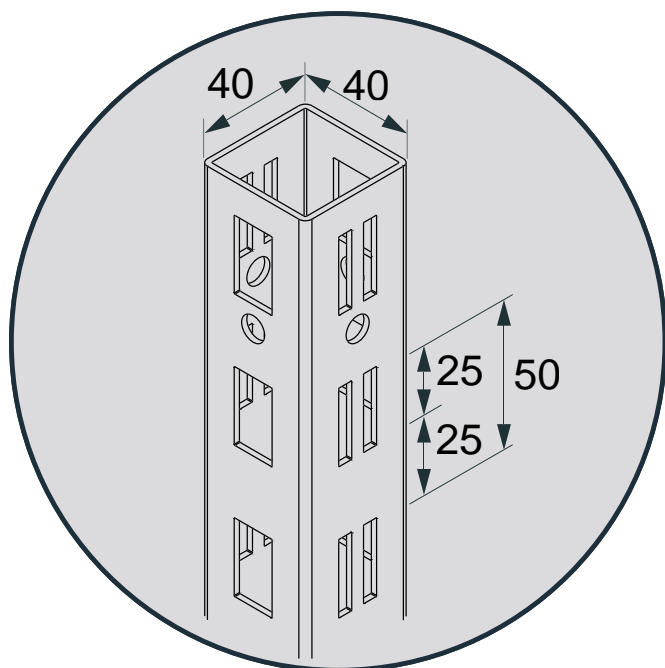



IWL25 RTBevo, wooden customization of the IMZ25 shelving line.

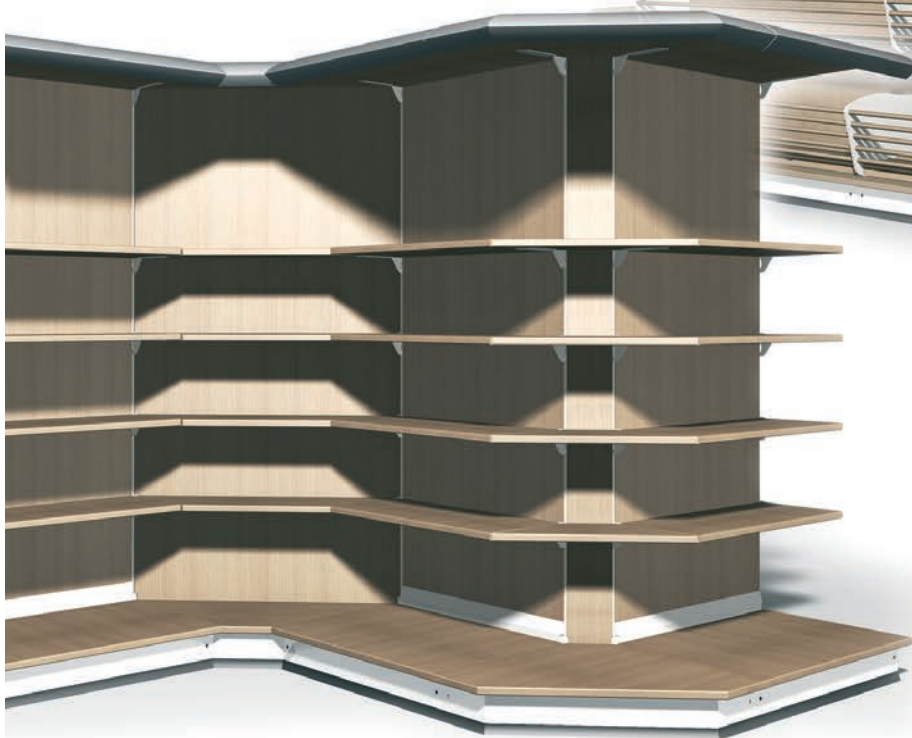
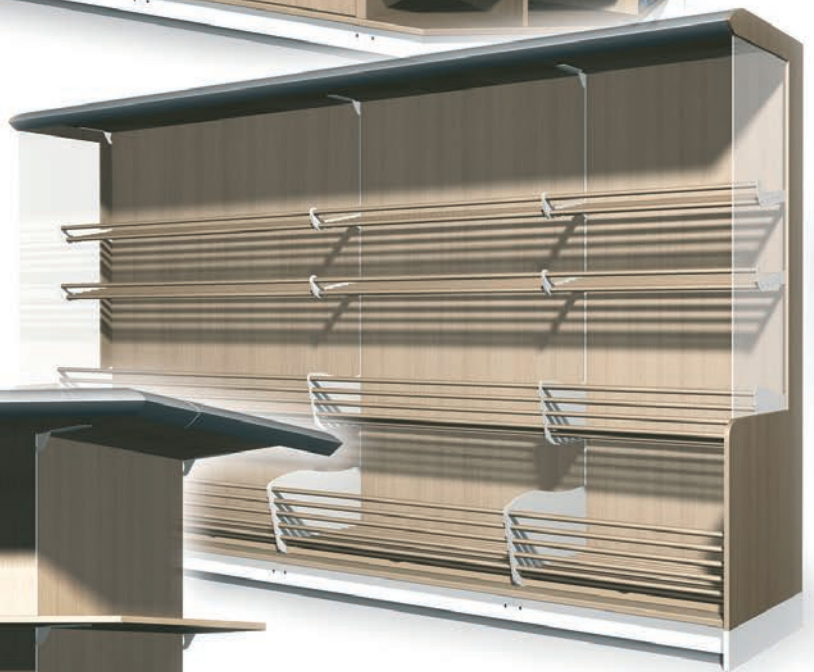



DOGMA25i-60, heavy duty shelving integrated with the IMZ25 shelving line.



DOGMA st-60, st-90, heavy duty shelving lines.



## Production

The production of the INTRAC checkout consist in 4 lines:

DIVA, design and minimalism for modern design solutions.

QUADRA, essential design for an efficient result.

RONDO, the revolutionary 'circular flow' counter,

ONDA, static or with motor-belt for small and medium retail areas.

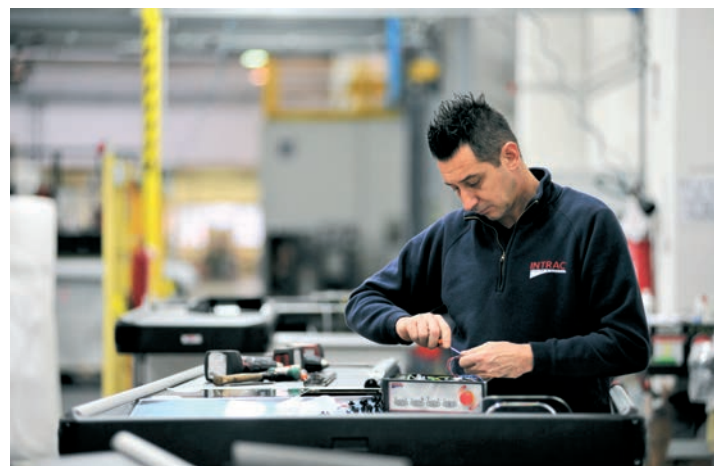



**DIVA**, design and minimalism for modern design solutions.

**QUADRA**, essential design for an efficient result.

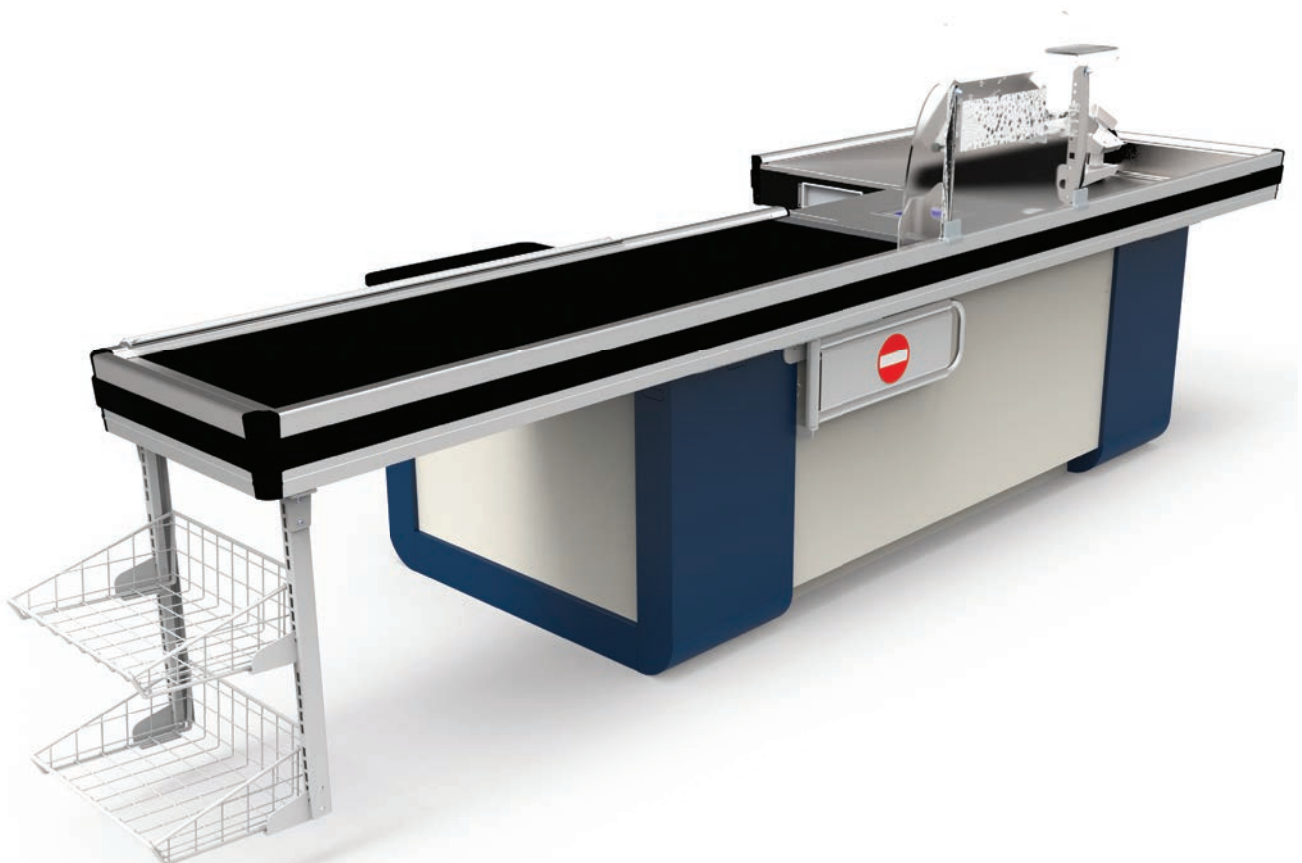

# RONDO



# RONDO'S

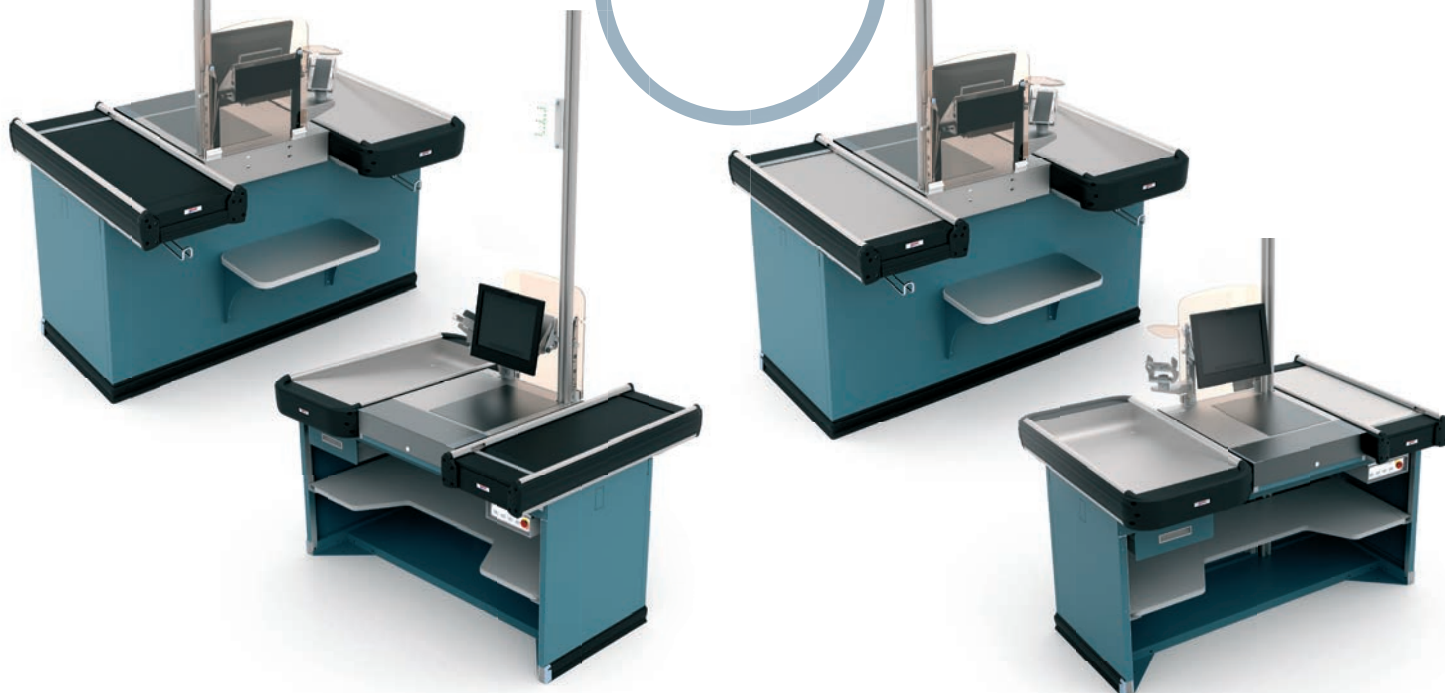

RONDO, the revolutionary 'circular flow' counter.

ONDA, static or with motor-belt for small and medium retail areas.



## Targets

This simple key concept represents our main target: the full satisfaction of those who place their trust in our competence.

INTRAC is an expert of both the small and the large scale distribution, and offers customised services from the initial stage of design till after sales assistance. The ideal partner if you want complete support at your service. Top quality and reliability are granted by our advanced know-how and constant research and updating.

Perceiving the current needs, anticipating the new trends and translating them into effective solutions is the challenge that INTRAC has always successfully faced.

We give value to your world.

# Welcome to EuroShop 2017



























INTRAC S.p.A.  
Via A. Grandi, 24  
45100 ROVIGO - Italy  
Tel. +39 0425 363666  
Fax +39 0425 363600  
[www.intrac.it](http://www.intrac.it) - [info@intrac.it](mailto:info@intrac.it)



L'INTRAC Spa, la cui politica è quella di un continuo perfezionamento, si riserva il diritto di apportare in qualunque momento modifiche ai dati contenuti in questa pubblicazione senza obbligo alcuno di avviso preventivo. • INTRAC Spa, in line with its policy of constant improvement, reserves the right to modify the data included in this catalogue at any time and without notice. • Die Firma INTRAC Spa, deren Politik eine stetige Verbesserung ihrer Produkte ist, behält sich das Recht vor, in irgendeinem Augenblick Inhaltsänderungen, ohne vorherige Benachrichtigungspflicht, in dem vorliegenden Katalog vorzunehmen. • INTRAC Spa, dont la politique est celle d'un perfectionnement continu, se réserve le droit d'apporter des modifications n'importe quand aux données contenues dans ce catalogue, sans aucune obligation de préavis de notre part. • A INTRAC Spa, cuja política de continuo aperfeiçoamento, reserva-se o direito de alterar em qualquer momento, a modificação de dados contidos nesta publicação, sem obrigação alguma de pré aviso. • INTRAC Spa, según su política de continuo refinamiento, se reserva el derecho de modificar los datos incluidos en este catálogo en cualquier momento y sin previo aviso. • Фирма INTRAC SPA, политикой которой является постоянное совершенствование, оставляет за собой право изменить все данные этого каталога в любой момент, без предварительного уведомления.